

Controller

Type EASYLAB TCU3

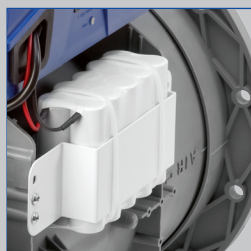

Plug sockets on the outside



Variant with battery pack



For laboratories



For hospitals



For clean rooms, e.g. in semiconductor manufacturing

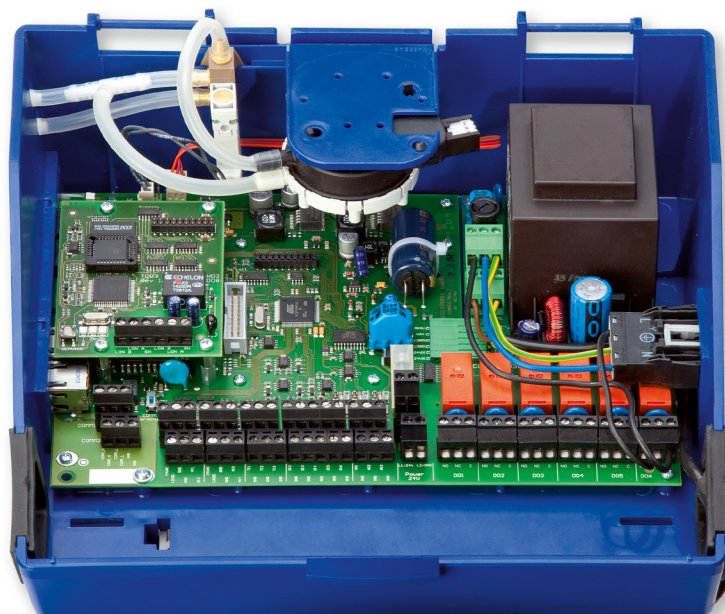

EASYLAB controllers for the most demanding control engineering tasks

Electronic controller that offers plug and play communication for demanding control tasks, yet simple wiring and commissioning

- Maximum control comfort for laboratories, clean rooms, hospital wards, and offices
- Perfect system for complete room solutions from a single source
- Demand-based and quick-response control for fume cupboards, and of supply air, extract air and pressure
- Interactive configuration software with commissioning wizard and Bluetooth adapter
- Plug-in communication cable for easy wiring
- Adaptable control panels and many special functions allow for individual operating modes and control strategies
- Fume cupboard control and monitoring according to EN 14175

Expansion options

- Connection to the mains (230 V)
- Expansion modules with LonWorks, BACnet or Modbus standard interfaces to the central BMS
- Automatic zero point correction for long-term stability and reduced maintenance
- Control panels for fume cupboards and for room control

Type		Page
EASYLAB TCU3	General information	TCU3 – 2
	Technical data	TCU3 – 4
	Specification text	TCU3 – 5
	Order code	TCU3 – 9
	Fume cupboard control	TCU3 – 12
	Extract air controller / supply air controller	TCU3 – 16
	Room control	TCU3 – 18
	Room management function	TCU3 – 22
	Interfaces	TCU3 – 23
	Product details	TCU3 – 26
	Installation details	TCU3 – 27
	Operation	TCU3 – 28

Application

Application

- Electronic controller Type EASYLAB TCU3 for the control of volume flow rates in fume cupboards and for the control of supply and extract air in laboratories; can also be used as an attachment for air terminal units
- For use in laboratories, clean rooms in the pharmaceutical and semiconductor industries, operating theatres, intensive care units, and offices with very demanding control requirements
- Fast and stable control of the volume flow rate for fume cupboards, and of room supply air and room extract air
- Fume cupboard control tested to EN 14175, part 6, for fume cupboards of all brands
- Controllers can be used individually or combined with other controllers for a complete room solution
- System solution for the volume flow control in rooms (room balance)
- For extract air led areas such as laboratories
- For supply air led areas such as clean rooms
- Numerous options for the integration of additional volume flows into the room balance
- Room pressure control or duct pressure control as cascade of differential pressure and volume flow rate
- Interface to the central BMS, voltage signals

0 – 10 V or with expansion modules for LonWorks, BACnet, Modbus

Special characteristics

- Plug and play communication system with automatic controller identification, no component addressing required
- Modular system for functional expansion
- Connections and status displays on the outside of the controller casing
- Project-specific adjustments are possible using adaptable control panel for fume cupboard and room
- Project-specific adjustments can be achieved with configurable special functions, monitoring, and alarm signalling
- Permanent function monitoring of the system and the connected sensors
- Very simple commissioning, configuration changes and diagnosis
- Centralised configuring and permanent signalling of room settings (room management function) on the TAM when combined with fume cupboards
- EasyConnect configuration software enables interactive navigation (also wireless)
- Factory tested and configured with project-specific parameters

Description

Equipment functions

Fume cupboard control

- FH-VS: Face velocity transducer – face velocity control
- FH-DS: Sash distance sensor – linear control strategy
- FH-DV: Sash distance sensor – safety-optimised control strategy
- FH-2P: 2 switching steps for on-site switch contacts
- FH-3P: 3 switching steps for on-site switch contacts
- FH-F: Volume flow rate constant value

Extract air controller / supply air controller

External volume flow rate setting

- EC/SC-E0: Volume flow rate default setting 0 – 10 V DC

- EC/SC-E2: Volume flow rate default setting 2 – 10 V DC

Without signalling

With switching steps for on-site switch contacts

- EC/SC-2P: 2 switching steps
- EC/SC-3P: 3 switching steps
- EC/SC-F: Volume flow rate constant value

Room control

Extract air led system for laboratories

- RS/LAB: Supply air control
- RE/LAB: Extract air control
- PC/LAB: Differential pressure control (supply air)

Supply air led system for clean rooms

- RS/CLR: Supply air control
- RE/CLR: Extract air control
- PC/CLR: Differential pressure control (extract air)

Parts and characteristics

- Ready-to-commission controller, as an attachment for air terminal units
- Static differential pressure transducer for rapid actual value measurement
- Fast-running high-precision actuator, running time for 90° is 3 s
- Microprocessor system with programme and system data stored in nonvolatile memory
- Double-stack terminal block for supply voltage connection
- Connections for two control panels
- Connection of communication line to plug socket or screw terminals
- Digital outputs with screw terminals
- Digital inputs with screw terminals or plug socket
- Analog inputs with screw terminals or plug socket
- Analog outputs with screw terminals or plug socket (actuator)
- Integral terminal resistor for the communication line
- Alarm indicator lights on both sides of the casing
- Status indicator lights (heartbeat, communication and terminal resistor)
- Equipment function FH-VS: Face velocity transducer VS-TRD for measuring the face velocity for fume cupboards
- Equipment function FH-DS, FH-DV: Sash distance sensor DS-TRD-01 for capturing the sash position of a fume cupboard

Attachments

Expansion modules are factory mounted or can be fitted at a later stage

- T: EM-TRF, power supply unit for connecting the controller to the 230 V AC mains voltage
- U: EM-TRF-USV, power supply unit for connecting the controller to the 230 V AC mains voltage and to ensure uninterrupted power supply
- Z: EM-AUTOZERO, automatic zero point correction for long-term stable volume flow rate measurement and hence reduced

maintenance.

- L: EM-LON, LonWorks FTT-10A interface
- B: EM-BAC-MOD-01, interface configured for BACnet MS/TP
- M: EM-BAC-MOD-01, interface configured for Modbus RTU
- S: EM-LIGHT, wired socket (230 V) for the connection of lighting and for switching the lighting on/off using the control panel
- EM-IP: BACnet-IP, Modbus-IP, webserviceinterface

Useful additions

- BE-SEG-**: Control panel for fume cupboard control
- BE-LCD-01: Control panel for fume cupboard control and room control
- TAM: Adapter module as an interface between fume cupboard control and room control, and to the central BMS
- Differential pressure transducers: Static differential pressure transducers for room pressure control or duct pressure control
- EasyConnect: Configuration software for the commissioning and diagnosis of EASYLAB components

Construction features

- Main PCB and expansion modules in one casing
- Controller casing is clip-fixed to the VAV terminal unit
- Controller casing can be opened without tools, except for TCU3 with EM-TRF or EM-TRF-USV
- Pin header socket for the connection of expansion modules
- Plug sockets for the most important connections on the outside of the casing
- Static differential pressure transducer with room air induction to protect the sensor

Materials and surfaces

- Casing made of ABS plastic, blue (RAL 5002)

Maintenance

- Zero point correction of the static differential pressure transducer should be carried out once per year (recommendation), except for EASYLAB TCU3 with EM-AUTOZERO expansion module

Supply voltage	24 V AC \pm 15 %; 230 V AC as option; 50/60 Hz
Power rating	35 VA fume cupboard controller with control panel; 29 VA room controller; 33 VA room controller with room control panel; max. 40 VA with all expansion modules
Micro fuse	2 A, slow blow, 250 V
Actuator	Fast-running high-precision actuator, running time for 90° is 3 s
Operating temperature	10 – 50 °C
IEC protection class	III (protective extra-low voltage)
Protection level	IP 20
EC conformity	EMC according to 2014/30/EU
Weight	1.4 kg

Recovery time	500 ms
2 interfaces for communication line	Network cable SF-UTP, 300 m max.; up to 24 devices
2 interfaces for control panels	Network cable SF-UTP, 40 m max.
6 digital inputs	for volt-free switch contacts; can be configured as make or break contacts
6 digital outputs	Relay with make/break contact, 250 V, 8 A; switch-on current 12 A
5 analog inputs	0 – 10 V, input resistance > 100 k Ω , characteristic can be configured
4 analog outputs	0 – 10 V, 10 mA max., characteristic can be configured

This specification text describes the general properties of the product. Texts for variants can be generated with our Easy Product Finder design programme.

Fume cupboard control

Circular VAV terminal units made of polypropylene (PPs), for variable air volume systems and fume cupboards. Suitable for the control of extract air containing aggressive media since all components coming into contact with the airflow are made of plastic (no interior metal parts).

Ready-to-operate unit consists of the mechanical parts and the electronic control components (attachments). Each unit contains a damper blade and an averaging effective pressure sensor with bluff body or a Venturi nozzle for volume flow rate measurement. Factory assembled control components (attachments) complete with wiring and tubing.

Effective pressure sensor with 3 mm measuring holes, hence resistant to dust and pollution.

Spigot, suitable for ducts according to DIN 8077. Position of the damper blade indicated externally at shaft extension.

Closed blade air leakage to EN 1751, class 4.

Casing air leakage to EN 1751, class C.

Materials and surfaces

- Casing made of ABS plastic, blue (RAL 5002)

Technical data

- Nominal sizes: 250 mm
- Volume flow rate range: 30 to 360 l/s or 108 to 1296 m³/h
- Volume flow rate control range: approx. 15 – 100 % of the nominal volume flow rate
- Differential pressure range: 5 – 1000 Pa

Control component (attachments)

Electronic controller for the demand-based control of variable volume flow rates in fume cupboards including the integrated monitoring of the aerodynamic function according to EN 14175 with optical and acoustic signalling.

Factory mounted onto the VAV terminal unit, complete with wiring and tubing, aerodynamically tested and factory set to the customer's parameters.

Equipment function:

FH-VS: Volume flow control on the basis of the measured face velocity and incorporating thermal loads. Monitoring of volume flow rate and face velocity.

Control electronics using a microprocessor, with configuration settings stored in EEPROM memory and hence safe in case of a power failure.

5 analog inputs, 6 volt-free digital inputs, 3 analog outputs, and 6 digital outputs as relay changeover contacts. Static differential pressure transducer with room air induction to protect the measurement point. Maintaining of the volume flow rates through a permanent setpoint/actual value comparison in a closed loop with a limitation

to minimum and maximum volume flow rates.

Connections for all important communication and peripheral devices are located on the outside of the casing and hence easily accessible. Indicator lights on the outside of the casing for alarms (on both sides), controller function (heartbeat), and communication.

Communication system with plug-in communication lines, automatic connection setup without manual network configuration, easy to expand with additional controllers (usually without integration issues).

Integration of variable or constant volume flow rates in the room balance using voltage signals, switch contacts or constant values. Signalling of volume flow rate actual values, damper blade positions, faults, and status messages to central BMS with analog or switch outputs.

Connection of one or two (for fume cupboards with sash windows on two sides) adaptable EASYLAB control panels BE-SEG-** or BE-LCD-01 with optical and acoustic signalling. Alarm sound can be deactivated or the duration can be limited.

Alarms and alarm signalling are configurable, e.g. suppressing alarms for certain operating modes or consolidating alarms from different levels.

Operating mode default setting by the central BMS, room control panel, or fume cupboard control panel, with flexible prioritisation and shut-off options. Supported special operating modes: increased operation, reduced operation, shut-off, and open position

Additional special functions

- Support of fume cupboards with supportive flow technology
- Safe control of an extract air scrubber
- Connection of motion detectors
- Smoke extract
- Control of the fume cupboard lighting
- Control of an automatic sash device
- Application of diversity factors when using EASYLAB TAM

5 analog inputs for connecting the sensor system and for integrating up to 4 variable volume flows. 6 volt-free digital inputs for the integration of constant volume flow rates and/or for the control of special functions.

3 analog outputs for signalling volume flow rate actual values and the controller damper blade position as well as the total volume flow rate for the room (supply air, extract air, or supply air setpoint value).

1 digital output for volume flow rate alarm with configurable alarm conditions.

5 digital outputs for various special functions.

Fast-running actuator (run time 90° < 3 s)

Supply voltage 24 V AC.

Extract air controller / supply air controller

Circular VAV terminal units for variable and constant volume flow systems, suitable for supply or extract air, available in 7 nominal sizes.

High control accuracy (even with upstream bend $R = 1D$).

Ready-to-operate unit consists of the mechanical parts and the electronic control components (attachments). Each unit contains an averaging effective pressure sensor for volume flow rate measurement, and a control damper blade.

Factory assembled control components (attachments) complete with wiring and tubing. Effective pressure sensor with 3 mm measuring holes, hence resistant to dust and pollution. Spigot with groove for lip seal, suitable for connecting ducts according to EN 1506 or EN 13180.

Position of the damper blade indicated externally at shaft extension.

Closed blade air leakage to EN 1751, class 4 (nominal size 100, class 2; nominal sizes 125 and 160, class 3).

Casing air leakage to EN 1751, class C

Materials and surfaces

- Casing made of ABS plastic, blue (RAL 5002)

Technical data

- Nominal sizes: 100 to 400 mm
- Volume flow rate range: 12 to 1680 l/s or 44 to 6048 m³/h
- Volume flow rate control range:
approx. 15 – 100 % of the nominal volume flow rate
- Differential pressure range: 5 – 1500 Pa

Control component (attachments)

Electronic controller for demand-based, variable volume flow control of supply or extract air in laboratories and for various tasks in hospitals and clean rooms.

Factory mounted onto the VAV terminal unit, complete with wiring and tubing, aerodynamically tested and factory set to the customer's parameters.

Equipment function:

EC/SC: Control of the demand-based supply air flow rate / extract air flow rate.

Up to 3 volume flow rate setpoint values can be stored on the controller and selected by an

external device; shut-off is also possible.

Setpoint value from an external unit (0(2) – 10 V DC signal) as an alternative.

Control electronics using a microprocessor, with configuration settings stored in EEPROM memory and hence safe in case of a power failure.

1 analog input, 6 volt-free digital inputs, 3 analog outputs, and 6 digital outputs as relay changeover contacts.

Static differential pressure transducer with room air induction to protect the measurement point.

Maintaining of the volume flow rates through a permanent setpoint/actual value comparison in a closed loop.

Connections for all important communication and peripheral devices are located on the outside of the casing and hence easily accessible.

Indicator lights on the outside of the casing for alarms (on both sides), controller function (heartbeat), and communication.

Communication system with plug-in communication lines, automatic connection setup without manual network configuration, easy to expand with additional controllers (usually without integration issues).

Signalling of volume flow rate actual values, damper blade positions, faults, and status messages to central BMS with analog or switch outputs.

Alarms and alarm signalling are configurable, e.g. suppressing alarms for certain operating modes or consolidating alarms from different levels. Up to 24 controllers can be connected to the communication line (fume cupboards, extract air, supply air, room controller).

Inputs and outputs

1 analog input for the default setting of a setpoint value from an external unit.

6 volt-free digital inputs.

3 analog outputs for the signalling of volume flow rate actual value and controller damper blade position as well as (optional) total extract air flow rate, total supply air flow rate, or total supply air flow rate setpoint value.

1 digital output for volume flow rate alarm with configurable alarm conditions.

Fast-running actuator (running time $90^\circ < 3$ s) supply voltage 24 V AC.

Room control

Circular VAV terminal units for variable and constant volume flow systems, suitable for supply or extract air, available in 7 nominal sizes.

High control accuracy (even with upstream bend $R = 1D$).

Ready-to-operate unit consists of the mechanical parts and the electronic control components (attachments). Each unit contains an averaging effective pressure sensor for volume flow rate measurement, and a control damper blade.

Factory assembled control components (attachments) complete with wiring and tubing. Effective pressure sensor with 3 mm measuring

holes, hence resistant to dust and pollution. Spigot with groove for lip seal, suitable for connecting ducts according to EN 1506 or EN 13180.

Position of the damper blade indicated externally at shaft extension.

Closed blade air leakage to EN 1751, class 4 (nominal size 100, class 2; nominal sizes 125 and 160, class 3).

Casing air leakage to EN 1751, class C

Materials and surfaces

- Casing made of ABS plastic, blue (RAL 5002)

Technical data

- Nominal sizes: 100 to 400 mm
- Volume flow rate range: 12 to 1680 l/s or 44 to 6048 m³/h
- Volume flow rate control range: approx. 15 – 100 % of the nominal volume flow rate
- Differential pressure range: 5 – 1500 Pa

Control component (attachments)

Electronic controller for demand-based, variable volume flow control of supply or extract air in laboratories and for various tasks in hospitals and clean rooms.

Factory mounted onto the VAV terminal unit, complete with wiring and tubing, aerodynamically tested and factory set to the customer's parameters.

Equipment function:

RS/LAB: Control of the demand-based supply air flow rate which results from the actual total extract air flow for the room; this strategy takes a user-defined difference into account in order to maintain the negative pressure in compliance with DIN 1946, part 7.

Control electronics using a microprocessor, with configuration settings stored in EEPROM memory and hence safe in case of a power failure.

5 analog inputs, 6 volt-free digital inputs, 3 analog outputs, and 6 digital outputs as relay changeover contacts. Static differential pressure transducer with room air induction to protect the measurement point. Maintaining of the volume flow rates through a permanent setpoint/actual value comparison in a closed loop with a limitation to minimum and maximum volume flow rates.

Connections for all important communication and peripheral devices are located on the outside of the casing and hence easily accessible. Indicator lights on the outside of the casing for alarms (on both sides), controller function (heartbeat), and communication.

Communication system with plug-in communication lines, automatic connection setup without manual network configuration, easy to expand with additional controllers (usually without integration issues).

Integration of variable or constant volume flow rates in the room balance using voltage signals, switch contacts or constant values. Signalling of volume flow rate actual values, damper blade positions, faults, and status messages to central BMS with analog or switch outputs.

Alarms and alarm signalling are configurable, e.g. suppressing alarms for certain operating modes or consolidating alarms from different levels.

Balancing of up to 24 EASYLAB controllers on the communication line (fume cupboards, extract air, supply air, other connections). Automatic distribution of the extract air or supply air flow rates across several EASYLAB volume flow controllers for one room; alternatively, distribution can be configured individually.

Control input signal for sun protection/blinds (to be provided by others) or for shut-off dampers (to be provided by others) for the volume flow rate dependent optimisation of the diffuser discharge

velocity

Inputs and outputs

4 analog inputs for integrating variable volume flows

6 digital inputs for integrating constant volume flow rates

3 analog outputs for the signalling of volume flow rate actual value and controller damper blade position as well as (optional) total extract air flow rate, total supply air flow rate, total supply air flow rate setpoint value

1 digital output for volume flow rate alarm with configurable alarm conditions

2 digital outputs for balancing volume flow rates at diffusers

Fast-running actuator (actuation time 90° < 3 s)

Supply voltage 24 V AC

Additional functions with active room management function

- Connection of one or two adjustable EASYLAB room control panels BE-LCD-01 (only for systems without a fume cupboard)
- Operating mode default setting for all controllers in the room
- Central interface point for individual or consolidated faults
- Monitoring of the room functions in case total extract air flow rate falls short of minimum value or total extract air flow rate exceeds maximum value (diversity)
- Limitation of the total extract air flow rate (diversity control)
- Operating mode default setting by the central BMS, room control panel, or fume cupboard control panel, with flexible prioritisation and shut-off options; special operating modes: increased operation, reduced operation, shut-off, and OPEN position
- Centralised configuring of room parameters
- Volume flow rate setpoint change based on temperature control or on external differential pressure control
- Connection of a room pressure transducer for pressure control
- Configurable consolidated alarms

Inputs and outputs

4 analog inputs for integrating a volume flow rate setpoint change based on temperature, a volume flow rate setpoint change based on pressure, and/or a differential pressure transducer for internal differential pressure control. Unused inputs can be used for integrating variable volume flow rates.

6 volt-free digital inputs for operating mode default setting, switching between two pressure setpoint values and/or a door contact. The remaining inputs which are not used otherwise can be used for integrating constant volume flow rates.

3 analog outputs for the signalling of volume flow rate actual value and controller damper blade position as well as (optional) total extract air flow rate, total supply air flow rate, or total supply air flow rate setpoint value

6 digital outputs for volume flow rate alarm, pressure alarm with internal differential pressure control, consolidated alarm, volume flow rate

optimisation at diffusers, or integration of sun protection/blinds and/or lighting or devices. Alarm

conditions can be configured.

TVLK with EASYPAC for fume cupboard control

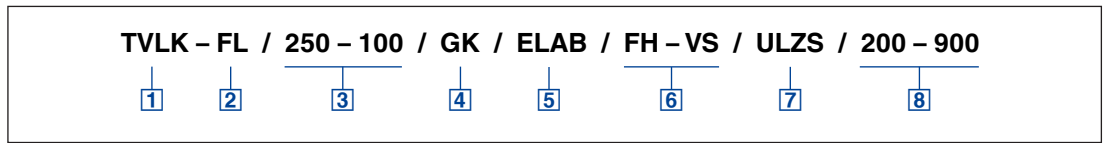

1 Type

TVLK VAV terminal unit, plastic

2 Flange

No entry: none

FL Flanges on both ends

3 Nominal size

250 – 100 Bluff body 100

250 – 160 Bluff body 160

250 – D08 Nozzle D08

250 – D10 Nozzle D10

250 – D16 Nozzle D16

4 Accessories

No entry: none

GK Matching flanges for both ends

5 Attachments (control component)

ELAB EASYPAC controller TCU3 with fast-running actuator

6 Equipment function

With face velocity transducer

FH-VS Face velocity control

With sash distance sensor

FH-DS Linear control strategy

FH-DV Safety-optimised control strategy

With switching steps for switch contacts provided by others

FH-2P 2 switching steps

FH-3P 3 switching steps

Without signalling

FH-F Volume flow rate constant value

7 Expansion modules

Option 1: Supply voltage

No entry: 24 V AC

T EM-TRF for 230 V AC

U EM-TRF-USV for 230 V AC, provides uninterruptible power supply (UPS)

Option 2: Communication interface

No entry: none

L EM-LON for LonWorks FTT-10A

B EM-BAC-MOD-01 for BACnet MS/TP

M EM-BAC-MOD-01 for Modbus RTU

I EM-IP for BACnet/IP, Modbus/IP and webserver

R EM-IP with real time clock

Option 3: Automatic zero point correction

No entry: none

Z EM-AUTOZERO Solenoid valve for automatic zero point correction

Option 4: Lighting

No entry: none

S EM-LIGHT Wired socket for the connection of lighting and for switching the lighting on/off using the control panel (only with EM-TRF or EM-TRF-USV)

8 Operating values [m³/h or l/s]

Depending on the equipment function

VS: $\dot{V}_{\min} - \dot{V}_{\max}$

DS: $\dot{V}_{\min} - \dot{V}_{\max}$

DV: $\dot{V}_{\min} - \dot{V}_{\max}$

2P: \dot{V}_1 / \dot{V}_2

3P: $\dot{V}_1 / \dot{V}_2 / \dot{V}_3$

F: \dot{V}_1

Useful additions

Control panel for fume cupboard controller, for displaying the functions of the control system according to EN 14175

BE-SEG-02 OLED display

BE-LCD-01 40-character display

TVR with EASYLAB for room control and single operation

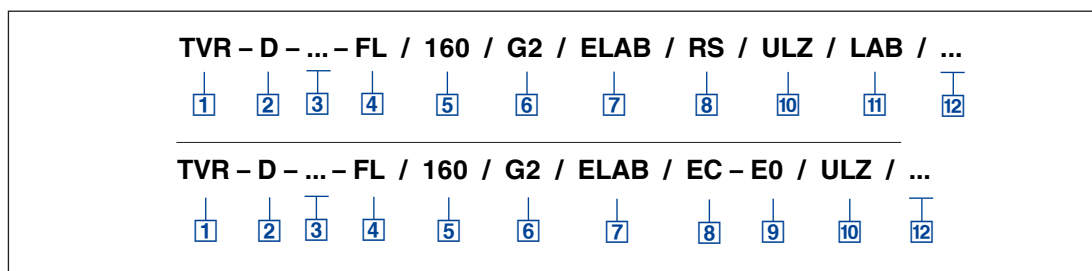

1 Type

TVR VAV terminal unit

2 Acoustic cladding

No entry: none

D With acoustic cladding

3 Material

No entry: galvanised sheet steel

P1 Powder-coated (RAL 7001), silver grey

A2 Stainless steel

4 Flange

No entry: none

FL Both ends (not for TVR-D-P1)

5 Nominal size [mm]

D_N

6 Accessories

No entry: none

D2 Lip seals on both ends

G2 Matching flanges for both ends

7 Attachments (control component)

ELAB EASYLAB controller TCU3 with fast-running actuator

8 Equipment function

Room control

RS Supply air control (Room Supply)

RE Extract air control (Room Exhaust)

PC Differential pressure control

Single operation

SC Supply air controller

EC Extract air controller

9 External volume flow rate setting

Only for single operation

E0 Voltage signal 0 – 10 V DC

E2 Voltage signal 2 – 10 V DC

2P On-site switch contacts for 2 switching steps

3P On-site switch contacts for 3 switching steps

F Volume flow rate constant value, without signalling

10 Module expansions

Option 1: Power supply

No entry: 24 V AC

U EM-TRF-USV for 230 V AC, provides uninterruptible power supply

Option 2: Communication interface

No entry: none

L EM-LON for LonWorks FTT-10A

B EM-BAC-MOD-01 for BACnet MS/TP

M EM-BAC-MOD-01 for Modbus RTU

I EM-IP for BACnet/IP, Modbus/IP and webservice

R EM-IP with real time clock

Option 3: Automatic zero point correction

No entry: none

Z EM-AUTOZERO with solenoid valve

11 Additional functions

Only for room control (equipment function)

RMF has been deactivated

LAB Extract air led system (laboratories)

CLR Supply air led system (clean rooms)

Raum management function is active

LAB-RMF Extract air led system (LAB)

CLR-RMF Supply air led system (CLR)

12 Operating values [m^3/h or l/s , Pa]

For equipment function 'room control' with additional function RMF

Total room extract air/supply air

\dot{V}_1 : Standard mode

\dot{V}_2 : Reduced operation

\dot{V}_3 : Increased operation

\dot{V}_4 : Constant room supply air

\dot{V}_5 : Constant room extract air

\dot{V}_6 : Supply air/extract air difference

Δp_{set} : Setpoint (only with pressure control)

For equipment function 'single operation'

$E0, E2: \dot{V}_{min} / \dot{V}_{max}$

$2P: \dot{V}_1 / \dot{V}_2$

$3P: \dot{V}_1 / \dot{V}_2 / \dot{V}_3$

$F: \dot{V}_1$

Useful additions

Room control panel

BE-LCD-01 40-character display

Order example: TVLK/250-100/ELAB/FH-VS/Z/200-900 m³/h

Flange	Without
Nominal size	250 with bluff body 100
Accessories	Without
Control component	EASYLAB controller TCU3 with fast-running actuator
Equipment function	Fume cupboard control with face velocity transducer
Expansion modules	EM-AUTOZERO Solenoid valve for automatic zero point correction
Operating values	200 – 900 m ³ /h

Order example: TVR/160/ELAB/RS/Z/LAB-RMF/1500/1000/2000/0/0/200 m³/h

Acoustic cladding	Without
Material	Galvanised sheet steel
Nominal size	160 mm
Flange	Without
Accessories	Without
Control component	EASYLAB controller TCU3 with fast-running actuator
Equipment function – room control	Room supply air
Expansion modules	EM-AUTOZERO Solenoid valve for automatic zero point correction
Additional function	Extract air led system with active room management function
Operating values	1500/1000/2000/0/0/200 m ³ /h

Fume cupboard control

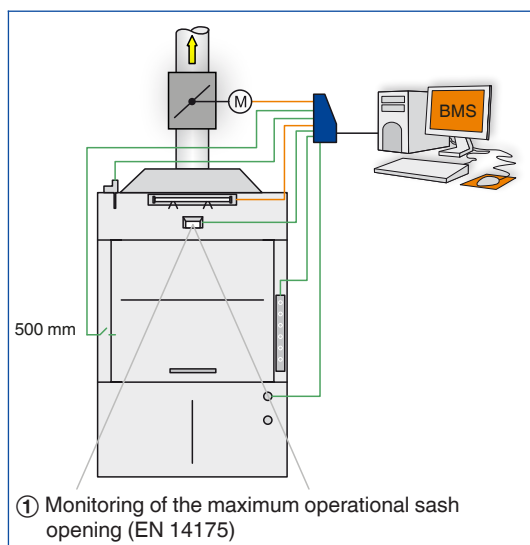

Fume cupboard control

Application

- Volume flow control for fume cupboards
- Combination with plastic VAV terminal units Type TVLK or Type TVRK, or with galvanised sheet steel VAV terminal units Type TVR
- Variable volume flow control to save energy while providing maximum safety
- Control tested to EN 14175, part 6, by an independent testing institute; applies to all fume cupboards that have been tested to EN 14175
- Volume flow rate setpoint values \dot{V}_{\min} and \dot{V}_{\max} based on fume cupboard tests to EN 14175, carried out by the respective fume cupboard manufacturers

Monitoring and alarm function

- Monitoring of the volume flow rate including configurable optical and acoustic alarms
- Optional monitoring of the face velocity, including configurable optical and acoustic alarms (only for equipment function FH-VS)
- Monitoring of the sash position and signalling when the sash is opened beyond the maximum operational sash opening (EN 14175).
- Optical and acoustic signalling of operating states on the EASYLAB control panel BE-SEG-** or BE-LCD-01
- Two control panels can be used for each fume cupboard controller, e.g. for fume cupboards with sash windows on two sides
- Acoustic signals can be switched off or the signalling period can be limited depending on the monitoring function
- Alarms can be individually configured, e.g. no alarm during reduced operation, flashing alarm, permanent light

Operating modes

- Standard mode with evaluation of the connected sensor system

- Special operating modes: Increased operation, reduced operation, shut-off, and OPEN position

Operating mode default setting

- Three levels for setting operating mode defaults (central BMS, room, fume cupboard)
- Configuration options for prioritisation and shut-off
- Operating mode default setting can affect all controllers in a room or a single controller, e.g. 24-hour operation
- Default setting from the central BMS using network variables (LonWorks, BACnet, Modbus) or with switch contacts: room operating mode or fume cupboard operating mode
- Default setting using the room control panel with switch contacts: room operating mode or fume cupboard operating mode
- Default setting using the fume cupboard control panel: fume cupboard operating mode

Special functions

- Application of diversity factors when using EASYLAB TAM
- Support of fume cupboards with supportive flow technology
- Support of the safe operation of extract air scrubbers
- Connection of a motion sensor to signal 'sash open' or to reduce the face velocity when nobody is working at the fume cupboard
- Smoke extract function for opening or closing the damper blade
- Control of an automatic sash device
- Control of the fume cupboard lighting from the control panel
- Setting the controller action in case the supply voltage fails (only with expansion module EM-TRF-USV)

Control diagram for FH-VS (EASYPAC) and FH (TCU-LON-II)

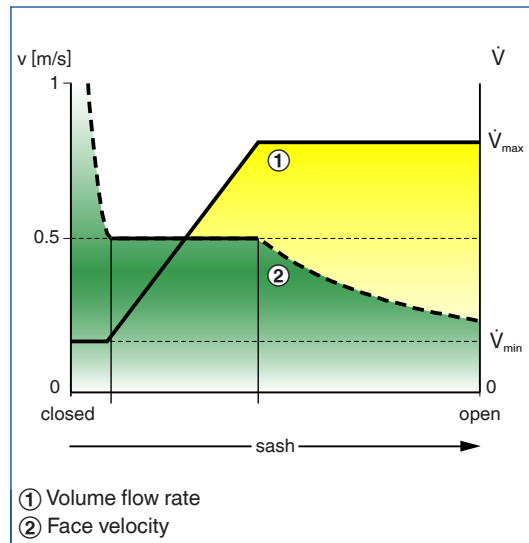

Control diagram for FH-DS

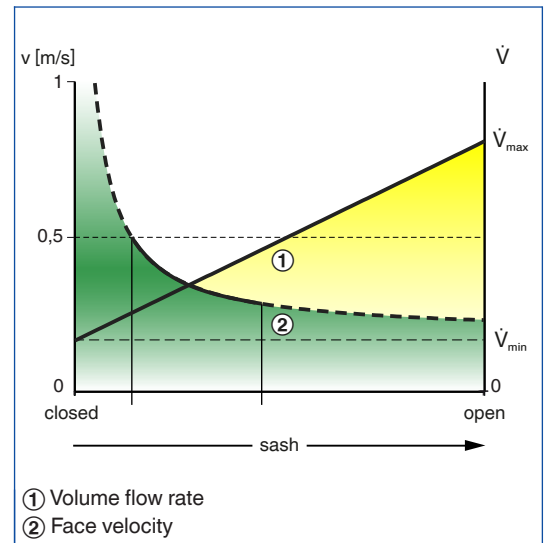

Face velocity control

- Variable volume flow control based on the measured face velocity
- Constant face velocity in a working range between \dot{V}_{min} and \dot{V}_{max}
- High thermal loads are detected and dissipated by an increased volume flow rate
- Face velocity can be monitored and displayed
- Non-contact measurement
- For fume cupboards with horizontal and vertical sashes

Linear control strategy

- Variable volume flow control based on the measured sash distance
- Volume flow rate is linear to the sash position: OPEN corresponds to \dot{V}_{max} , CLOSED corresponds to \dot{V}_{min}
- Particularly suitable for fume cupboards in rooms with increased airflow (turbulence)
- Sash opening can be monitored according to EN 14175, without additional switch contact

Control diagram for FH-DV

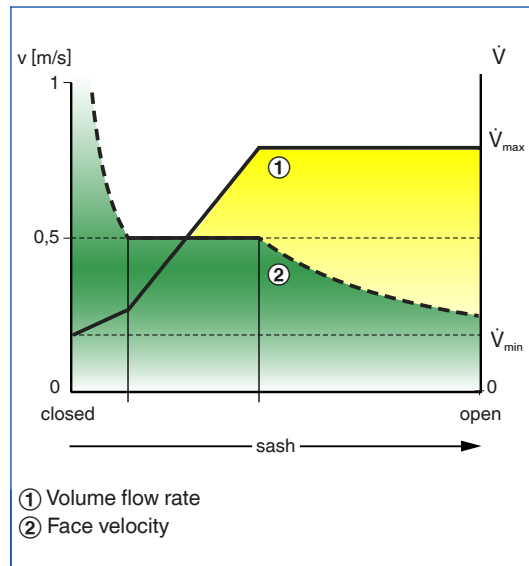

Control diagram FH-3P

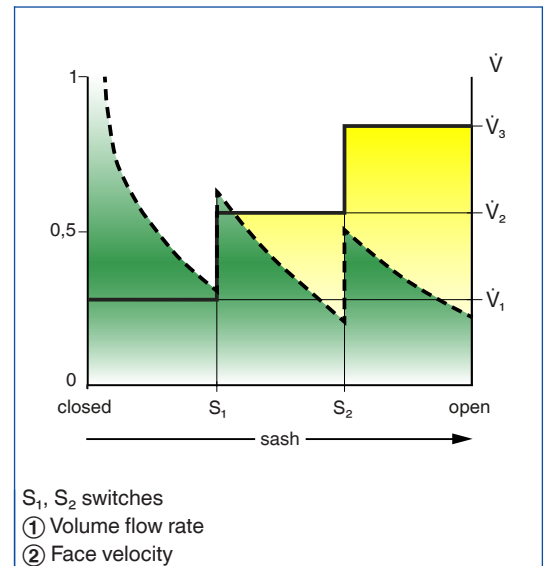

Safety-optimised control strategy

- Safety-optimised volume flow control based on the measured sash distance
- The volume flow rate is linear to the sash position; the aim is to maintain a constant safe face velocity (0.5 m/s) even if the sash is fairly wide open
- Particularly suitable for fume cupboards in rooms with increased airflow (turbulence)
- Sash opening can be monitored according to EN 14175, without additional switch contact

Three switching steps

- Volume flow control with three setpoint values
- Switching with two switch contacts (to be provided by others)
- Switch contact for sash distance monitoring according to EN 14175 can be used for one switching step

Control diagram FH-2P

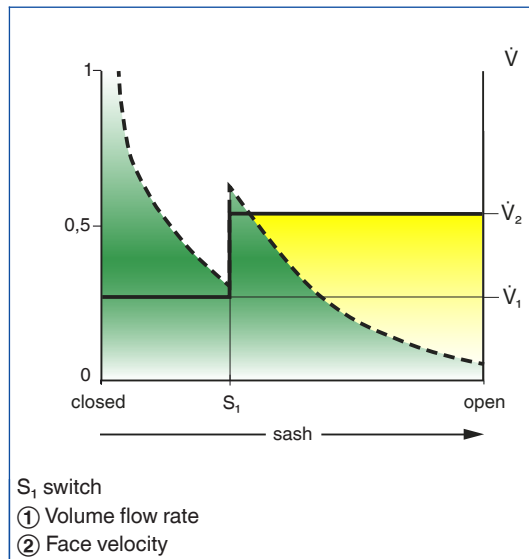

- Two switching steps
- Volume flow control with two setpoint values
 - Switching with a switch contact (to be provided by others)

Control diagram FH-F

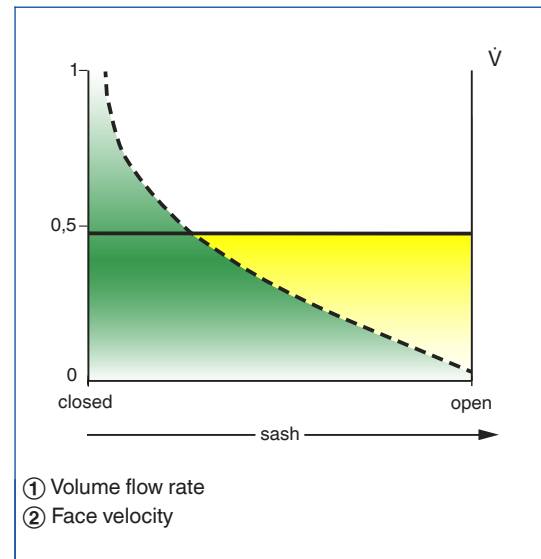

- Volume flow rate constant value
- Volume flow control with a constant setpoint value

Diversity control

- In many large laboratories the simultaneous operation of all controllers at maximum power is either not desirable or not possible because of the limited capacity of the system
- Diversity control allows for the safe and economical operation of such systems
- With the room management function the total extract air flow rate can be monitored and limited if it exceeds a certain value
- Configuration is done on the TAM with room management function
- Available with EASYLAB TAM in extract air led systems (LAB)

Monitoring of the total extract air flow rate

- The total extract air flow rate is monitored
- An optical alarm is emitted on the room control panel

- Alarms are consolidated for signalling

Limiting the total extract air flow rate

- The total extract air flow rate is monitored
- If it exceeds a certain value, the volume flow rate is reduced for individual fume cupboards, and the total volume flow rate is limited as a consequence
- Reducing the volume flow rate for only selected fume cupboards ensures that as many fume cupboards as possible can be safely used at the same time
- Optical and acoustic alarms are emitted on the fume cupboard for which the volume flow rate has been reduced
- An optical alarm is emitted on the room control panel
- Alarms are consolidated for signalling

Diversity control

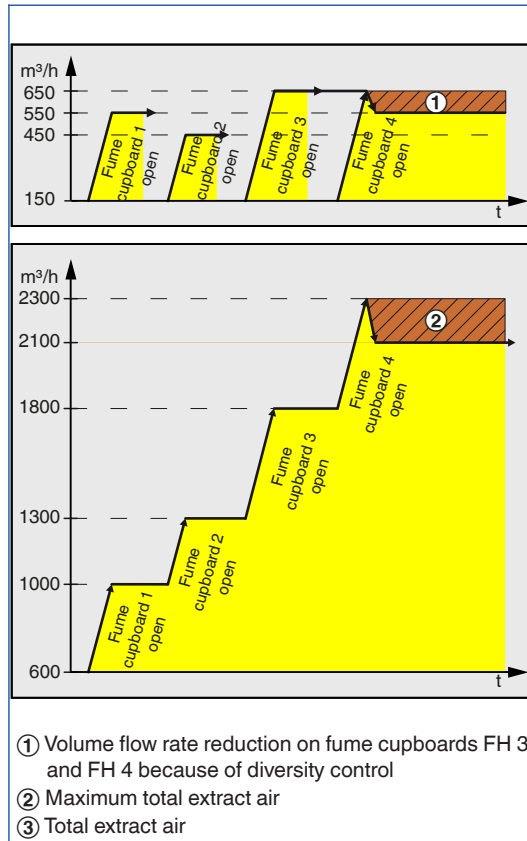

Extract air controller / supply air controller

Application

- Extract air and supply air volume flow rate control and volume flow rate measurement
- Combination with plastic VAV terminal units Type TVLK, TVRK, VMRK or VMLK or galvanised sheet steel VAV terminal units Type TVR, TVJ, TVT, TVA, TVZ, or VMR
- Variable volume flow control to save energy while providing maximum safety

Monitoring and alarm function

- Monitoring of the volume flow rate can be configured
- Alarms can be individually configured, e.g. no alarm during reduced operation
- Alarms can be displayed on an external unit, e.g. on an explosion-proof control panel

Operating modes

- Standard operation with variable volume flow rate default setting using DC signal; alternatively, with 2 or 3 volume flow rate ranges (using 1 or 2 switches), or with a

constant setpoint value

- Special operating modes: Increased operation, reduced operation, shut-off, and OPEN position

Operating mode default setting

- Three levels for setting operating mode defaults (central BMS, room, digital inputs on the controller)
- Configuration options for prioritisation and shut-off
- Operating mode default setting can affect all controllers in a room or a single controller, e.g. 24-hour operation
- Default setting from the central BMS using network variables (LonWorks, BACnet, Modbus) or with switch contacts: room operating mode or controller mode

Special functions

- Setting the controller action in case the supply voltage fails (only with expansion module EM-TRF-USV)

Control diagram for EC/SC-E0/E2

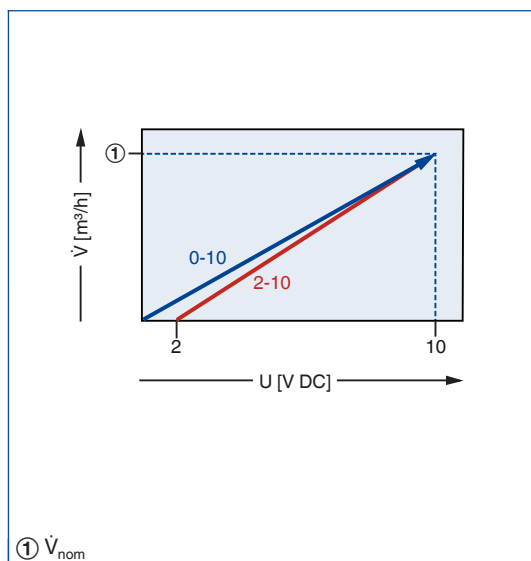

Variable control

- Variable default setting of volume flow rates using 0 (2) – 10 V DC signals
- Signal default setting by others

Control diagram for EC/SC-3P

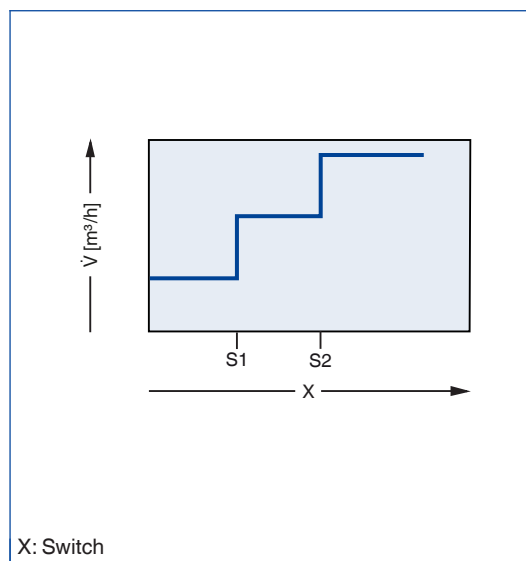

Three switching steps

- Volume flow control with three setpoint values
- Switching with two switch contacts (to be provided by others)

Control diagram for EC/SC-2P

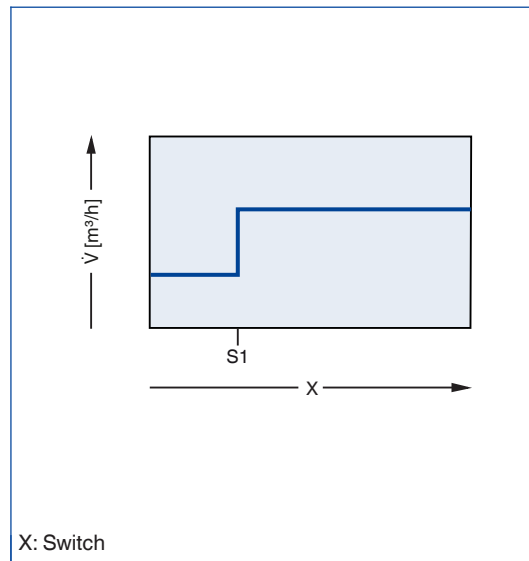

Control diagram for EC/SC-F

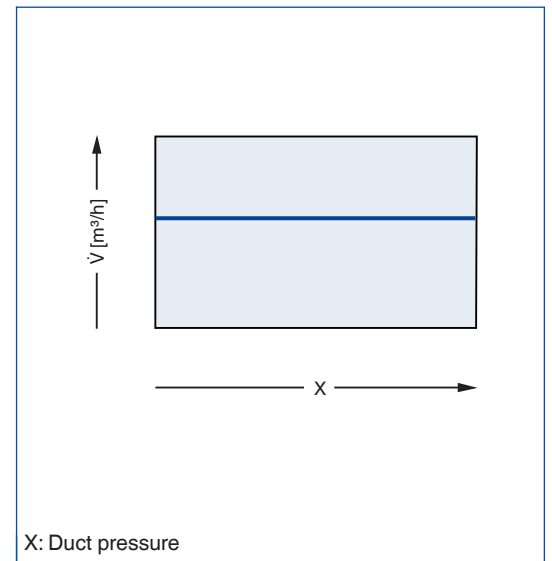

Two switching steps

- Volume flow control with two setpoint values
- Switching with a switch contact (to be provided by others)

Volume flow rate constant value

- Volume flow control with a constant setpoint value

Supply air control (example)

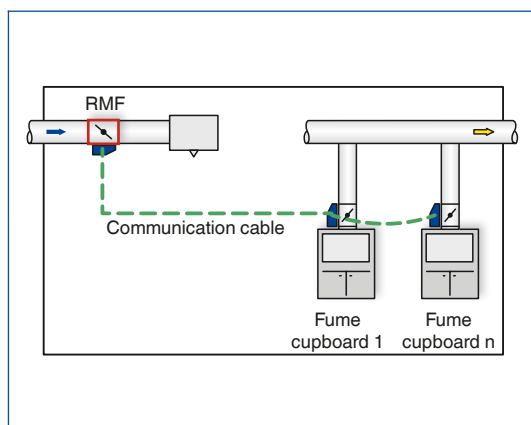

Extract air control (example)

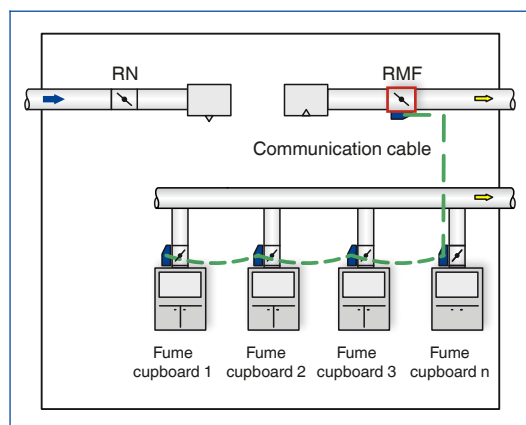

Room control

Application

- Variable supply air or extract air flow control for areas where quick-response and stable control is required, e.g. laboratories, clean rooms, hospital wards, and offices with demanding requirements
- Can be combined with VAV terminal units Type TVR, TVRK, TVJ, TVT, TVZ, or TVA
- EASYLAB room control with supply air led and extract air led systems can be configured for two specific applications
- Extract air led system: Rooms with negative pressure, e.g. laboratories
- Supply air led system: Rooms with positive pressure, e.g. clean rooms
- The controllers for a room must be suitable for the selected system, e.g. supply air controllers for RS/.../LAB, extract air controllers for RE/.../LAB
- Fume cupboard controllers can be used with both systems

Extract air led system (LAB)

- Sizing is based on the minimum total extract air for a room, e.g. to DIN 1946, part 7, 25 m³/h per m²
- Room control aims to maintain the minimum total extract air flow rate
- The extract air controller (master) controls the room extract air flow rate
- The supply air controller (slave) controls the supply air flow rate based on demand and depending on the actual total extract air flow rate
- As an option, the supply air controller can be used to control the differential pressure

Supply air led system (CLR)

- Sizing is based on the total supply air
- Room control aims to maintain the total supply air flow rate
- The supply air controller (master) controls the room supply air flow rate
- The extract air controller (slave) controls the room extract air flow rate based on demand and depending on the actual total extract air

flow rate

- As an option, the extract air controller can be used to control the differential pressure

Volume flow rate balancing

- All supply air and extract air flow rates for a room are recorded and added together
- Up to 24 EASYLAB controllers
- Variable volume flow rate signals (voltage signals or network variables LonWorks, BACnet, Modbus)
- Constant volume flow rates can be integrated (using digital inputs)
- Constant volume flow rates (set parameters)

Room pressure or duct pressure control

- Linking volume flow rate balancing with differential pressure control by connecting a differential pressure transducer (room pressure)
- Switching between two pressure setpoint values
- Switching between setpoint values by means of switch contact or network variables LonWorks, BACnet, Modbus
- Adding of a door contact in order to optimise the control function and to emit an alarm when the door is open

Functions

- Stable room balance due to quick-response control
- Volume flow rate monitoring with optical alarm on the controller casing, as well as configurable alarm signalling
- Room operating mode can be overridden by an individual operating mode
- Extract air balance is optimised by a reduction of the room extract air if enough air is already extracted by fume cupboards (extract air led system)
- Automatic supply air or extract air flow distribution where several EASYLAB controllers are installed in a room; distribution according to identical or different volume flow rates (percentages)
- Controlled response in case of a power failure can be defined (EASYLAB TCU3 with

- expansion module EM-TRF-USV)
- Control input signal for sun protection/blinds (to be provided by others) or for shut-off dampers (to be provided by others) for the volume flow rate dependent optimisation of the diffuser discharge velocity

Operating modes

- Standard mode
- Special operating modes: Increased operation,

Control diagram for supply air control RS/.../LAB

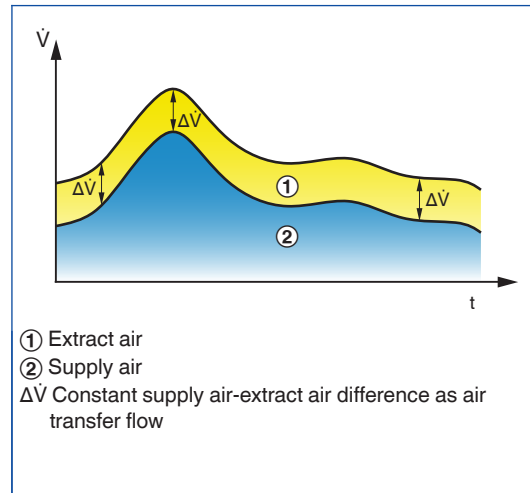

Supply air control in an extract air led system

- Control of the demand-based supply air flow rate which results from the actual total extract air flow for the room
- This strategy takes a user-defined difference into account in order to maintain the negative pressure in compliance with DIN 1946, part 7
- Supply air controller = slave

- reduced operation, shut-off, and OPEN position
- Room operating mode is defaulted

Special functions

Room management function

- Central room interface
- Centralised configuring of room parameters
- Connection of room control panels

Control diagram for equipment function RE/.../LAB

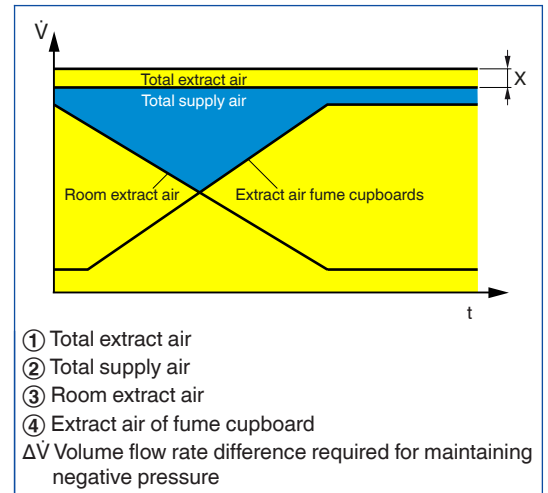

Differential pressure control in an extract air led system

- Linking of the room air balance control with the differential pressure control to quickly achieve a balanced and stable pressure
- The difference between supply air and extract air is variable in the case of differential pressure control
- Differential pressure is controlled by supply air controllers
- Area of application: Maintaining negative pressure in laboratories, for example

Control diagram

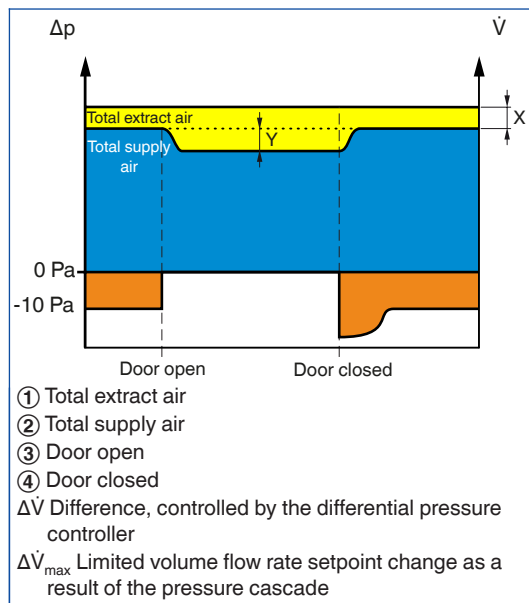

Control diagram for equipment function RE/.../CLR

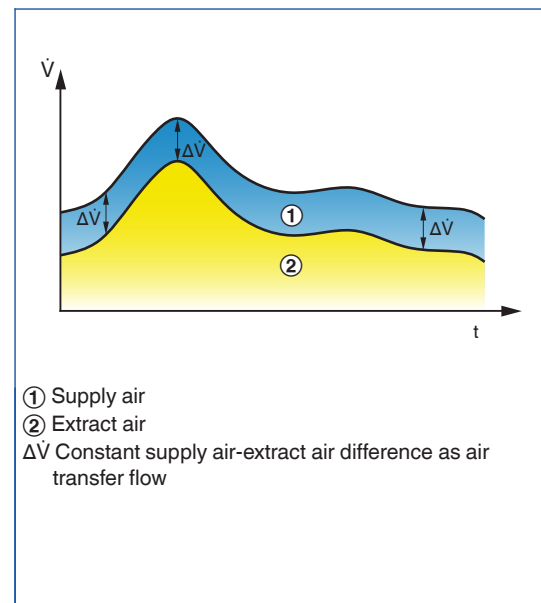

Differential pressure control in an extract air led system

- Linking of the room air balance control with the differential pressure control to quickly achieve a balanced and stable pressure
- The difference between supply air and extract air is variable in the case of differential pressure control
- Differential pressure is controlled by supply air controllers
- Area of application: Maintaining negative pressure in laboratories, for example

Extract air control in a supply air led system

- Control of the demand-based extract air flow rate which results from the actual total supply air flow rate for the room
- This strategy takes a user-defined difference into account in order to maintain a positive pressure
- Extract air controller = slave

Control diagram for equipment function RS/
.../CLR

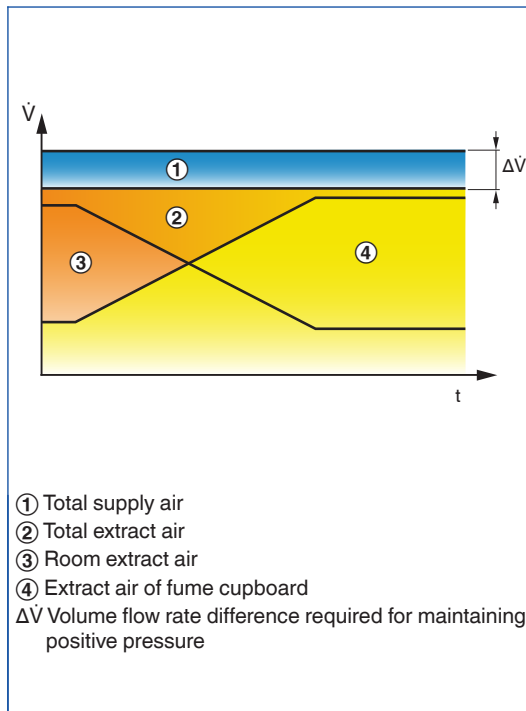

- Supply air control in a supply air led system
- Control of the room supply air and limitation of the total supply air flow rate for the room
 - The volume flow rates of all supply air controllers, the constant extract air, and the additionally integrated supply air are taken into consideration
 - If the total supply air flow rate is not sufficient, the room supply air is controlled accordingly
 - Supply air controller = master

Control diagram for equipment function PC/
.../CLR

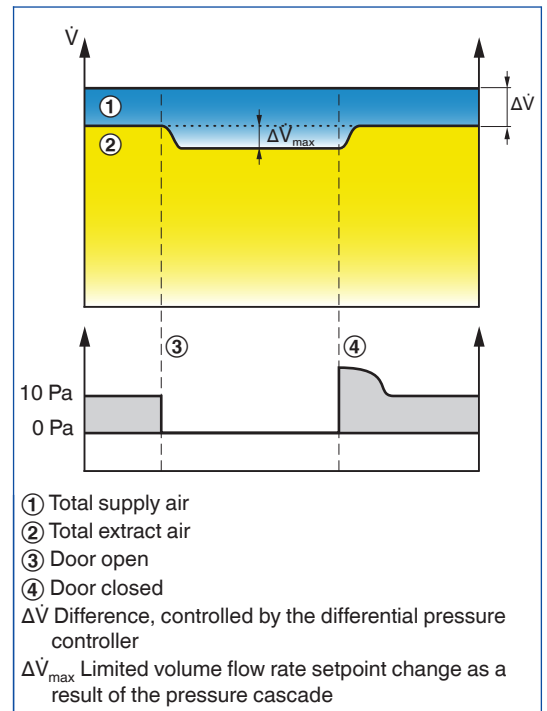

- Differential pressure control in a supply air led system
- Linking of the room air balance control with the differential pressure control to quickly achieve a balanced and stable pressure
 - The difference between extract and supply air is variable in the case of differential pressure control.
 - Differential pressure is controlled by extract air controllers
 - Area of application: Maintaining positive pressure in clean rooms, for example

Room management function RMF

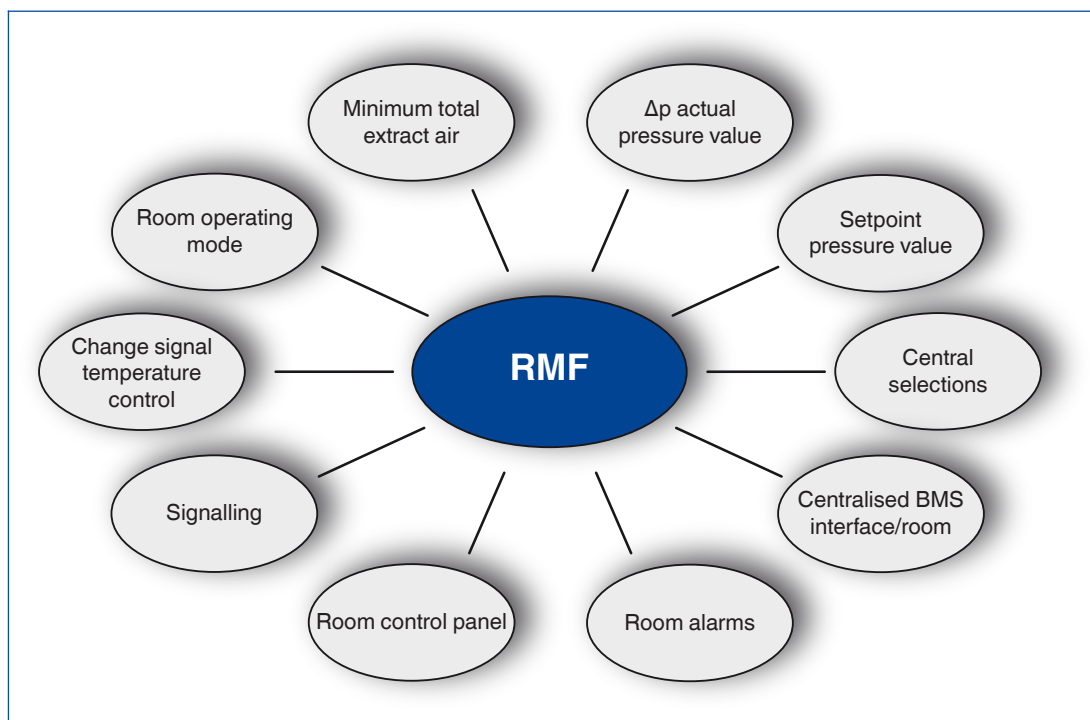

Room management function

Application

- The room management function is a software option that provides functions for the entire room
- Within an EASYPAC system with a maximum of 24 controllers, the room management function is activated on one controller – supply air controller TCU3, extract air controller TCU3, or TAM adapter module
- For fume cupboards, the room management function can only be activated on the TAM adapter module
- Factory set parameters for the room management function
- On-site activation using the EasyConnect configuration software

Central interface point for room functions

- Room operating mode default setting for all controllers in the room; priority can be selected
- Room operating mode default setting using switch contacts LonWorks, BACnet, Modbus, or room control panel
- Volume flow rate setpoint change based on temperature control
- Volume flow rate setpoint change based on external differential pressure control
- Connection of a room pressure transducer, door contact, and setpoint value switching contact for internal differential pressure control
- Control input signal for sun protection/blinds (to be provided by others) and lighting

Centralised configuring of the room

parameters and functions

- Default setting for the minimum total extract air or the minimum total supply air for the room
- Default setting for the supply air-extract air difference
- Default setting for differential pressure control parameters
- Incorporation of constant, non-switched volume flow rates
- Extract air balance optimisation

Monitoring of room functions

- Exceeding of the specified total extract air (monitoring of diversity) or limitation of the specified total extract air (diversity control)

Configurable consolidated alarms

- Consolidated alarm means that all alarms for all controllers of an EASYPAC system are consolidated

Use of room control panels

- Connection of 2 BE-LCD-01 room control panels
- Status display for the volume flow rate or differential pressure control of a room, e.g. pressure setpoint value and pressure actual value
- Display of actual room parameters, e.g. the actual and setpoint values for the total extract air flow rate
- Service interface for accessing room parameters
- Control of sun protection/blinds (to be provided by others) and lighting

Fume cupboard control

Inputs

- 4 analog inputs
 - Up to 4 analog inputs with configurable characteristics for the integration of variable flows
 - 3 inputs for equipment functions FH-VS, FH-DS, and FH-DV
 - 4 inputs for equipment functions FH-2P, FH-3P, and FH-F
- 6 digital inputs
 - The table below shows the available equipment functions, special functions, and the number of inputs required

Outputs

- 3 analog outputs
 - Volume flow rate actual value
 - Damper blade position
 - Total extract air flow rate, total supply air flow rate, or total supply air flow rate setpoint value
- 6 digital outputs
 - Alarm state
 - Control of extract air scrubbers, supportive flow technology, automatic sash device, and fume cupboard lighting

- Modbus RTU (EM-BAC-MOD-01)
- BACNET-IP (EM-IP)
- Modbus-IP (EM-IP)
- Webserver (EM-IP)

The following operating values and fault messages of the fume cupboard controller are signalled via the network:

- Volume flow rate actual value and setpoint value
- Damper blade position
- Operating mode
- Face velocity actual value and setpoint value
- Sash opening (FH-DS and FH-DV)
- Switching step (FH-2P and FH-3P)
- Alarm state
- Switching state of the digital inputs and outputs
- Number of controllers within the EASYLAB system
- Total extract air and total supply air volume flow rates
- Evaluated damper blade positions within the system

In addition, extract air and supply air volume flow rates can be permanently integrated into the room balance.

Expansion modules as interfaces to the central BMS

- LonWorks FTT-10A (EM-LON)
- BACnet MS/TP (EM-BAC-MOD-01)

Equipment functions and special functions for which digital switching inputs are required

Function	Required inputs
Fume cupboard control with 2 switching steps (FH-2P)	1
Fume cupboard control with 3 switching steps (FH-3P)	up to 2
Monitoring of the maximum operational sash opening (EN 14175 for FH-VS, FH-2P, FH-3P, FH-F)	1
Activation of extract air scrubber	1
Fume cupboards with supportive flow technology	1
Motion detector	1
Smoke extract	1
Operating mode default setting using switch contacts (only for fume cupboards to which the room operating mode does not apply)	1 per operating mode
Integration of constant volume flow rates using switch contacts	1 per volume flow rate

Extract air controller / supply air controller

Inputs

- 1 analog input
 - Equipment function EC/SC-E0 or EC/SC-E2: 1 analog input (AI4) for defaulting the volume flow rate setpoint value
- 6 digital inputs
 - The table below shows the available equipment functions, special functions, and the number of inputs required

- Volume flow rate actual value
- Damper blade position
- Total extract air flow rate, total supply air flow rate, or total supply air flow rate setpoint value

- 6 digital outputs
- Available functions:
 - Alarm state

Outputs

- 3 analog outputs

Expansion modules as interfaces to the central BMS

- LonWorks FTT-10A (EM-LON)
- BACnet MS/TP (EM-BAC-MOD-01)
- Modbus RTU (EM-BAC-MOD-01)
- BACNET-IP (EM-IP)

- Modbus-IP (EM-IP)
- Webserver (EM-IP)

The following operating values and fault messages of the extract air or supply air controller are transferred via the network:

- Volume flow rate actual value and setpoint value
- Damper blade position
- Operating mode
- Alarm state
- Switching state of the digital inputs and outputs

- Number of controllers within the EASYLAB system
- Total supply air and/or total extract air actual values
- Evaluated damper blade position
- Switching step (EC/SC-2P and EC/SC-3P)

Equipment functions and special functions for which digital switching inputs are required

Function	Required inputs
Extract air / supply air control with 2 setpoint values (EC/SC-2P)	1 DI
Extract air / supply air control with 3 setpoint values (EC/SC-3P)	2 DI
Extract air / supply air control with constant value (EC/SC-F)	0 DI

Room control

Inputs

4 analog inputs

- Analog inputs with configurable characteristics for the integration of variable air volume flows

6 digital inputs

- Digital inputs for the integration of constant volume flow rates using switch contacts

Outputs

3 analog outputs

- Volume flow rate actual value
- Controller damper blade position
- Total extract air flow rate, total supply air flow rate, or total supply air flow rate setpoint value (extract air led system)

3 digital outputs

Available functions:

- Alarm state
- Control input signal for shut-off dampers for the volume flow rate dependent optimisation of the diffuser discharge velocity (only equipment function RS)

- BACnet MS/TP (EM-BAC-MOD-01)
- Modbus RTU (EM-BAC-MOD-01)
- BACNET-IP (EM-IP)
- Modbus-IP (EM-IP)
- Webserver (EM-IP)

The following operating values and fault messages of the room controller are transferred via the network:

- Volume flow rate actual value and setpoint value
- Damper blade position
- Operating mode
- Alarm state
- Switching state of the digital inputs and outputs
- Number of controllers within the EASYLAB system
- Total supply air and/or total extract air actual values
- Evaluated damper blade position

In addition, extract air or supply air volume flows can be permanently integrated into the room balance.

Expansion modules as interfaces to the central BMS

- LonWorks FTT-10A (EM-LON)

Room management function

Inputs

4 analog inputs

- Volume flow rate setpoint change based on temperature control
- Volume flow rate setpoint change based on external differential pressure control
- Room pressure actual value for internal differential pressure control
- Connection of variable volume flow rates at inputs that are not used otherwise

6 digital inputs

Available functions:

- Room operating mode default setting: Standard mode, reduced operation, increased operation, shut-off, and OPEN position
- Prioritisation of the room operating mode: by the central BMS or locally
- Switching between two pressure setpoint values in case of internal differential pressure control
- Incorporation of a door contact for internal

differential pressure control

- Integration of temporarily constant volume flow rates at inputs that are not used otherwise

Outputs

3 analog outputs

- Volume flow rate actual value for the controller
- Controller damper blade position
- Total extract air flow rate, total supply air flow rate, or total supply air flow rate setpoint value

6 digital outputs

- Alarm for the local controller
- Consolidated alarm for the room
- Differential pressure alarm (only for internal differential pressure control)
- Control input signal for sun protection/blinds (to be provided by others) or for shut-off dampers (to be provided by others) for the volume flow rate dependent optimisation of the diffuser discharge velocity
- Connection of lighting (to be provided by others)

Expansion modules as interfaces to the central BMS

- LonWorks FTT-10A (EM-LON)
- BACnet MS/TP (EM-BAC-MOD-01)
- Modbus RTU (EM-BAC-MOD-01)
- BACNET-IP (EM-IP)
- Modbus-IP (EM-IP)
- Webserver (EM-IP)

The following operating values and fault messages for the room are transferred via the network:

- Operating mode default setting
- Prioritisation of operating mode default settings (central BMS, locally)
- Integration of a volume flow rate setpoint change with regard to temperature or differential pressure control
- Switching between two pressure setpoint values
- Integration of extract air and/or supply air flow rate values for room balancing
- Control input signal for sun protection/blinds (to be provided by others)

Feedback signals from the EASYLAB system (room):

- Room operating mode
- Total extract air flow rate actual value
- Total supply air flow rate actual value
- Evaluated damper blade positions
- Consolidated alarm
- Setpoint and actual values of the internal room pressure control
- Room pressure alarm

Connections and status displays

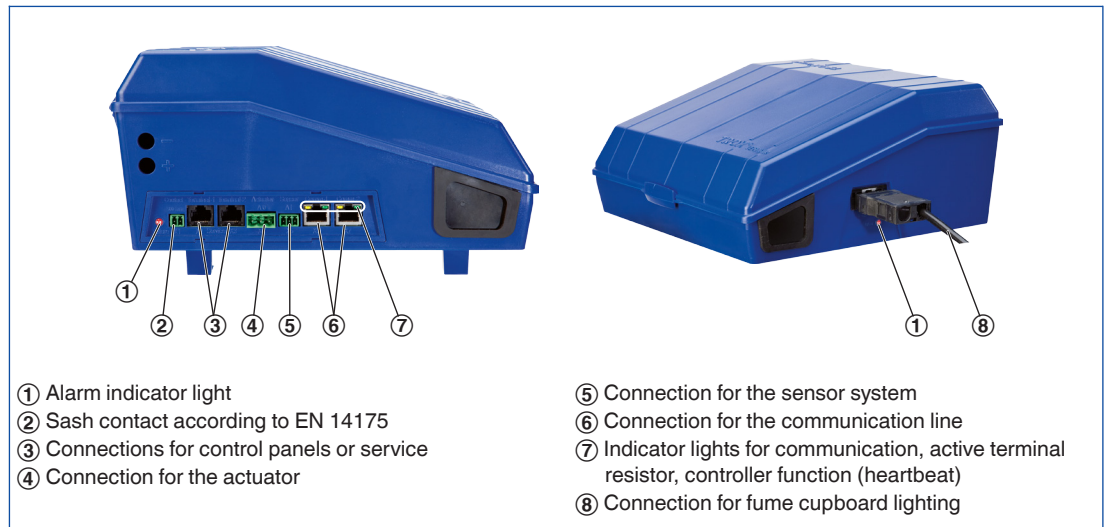

Installation and commissioning

- Any installation orientation (some installation orientations may require adjusting the position of the differential pressure transducer in the controller casing)
- Carry out zero point correction of the static differential pressure transducer, except for EASYPYLAB TCU3 with EM-AUTOZERO expansion module
- Connect communication line and activate terminal resistors at both ends
- Component addressing and network management tool are not required
- If necessary, make adjustments using the EasyConnect configuration software
- Set parameters for the room control

Fume cupboard control

- Install and connect (plug connection) the sensor system and the control panel

Extract air controller / supply air controller

- Connect on-site switch contacts or setpoint signal

Room control

- Enter room control parameters at one controller (room management function)
- For fume cupboards, the room management function can only be activated on the TAM adapter module

Measurement location of the face velocity transducer (FH-VS, FH)

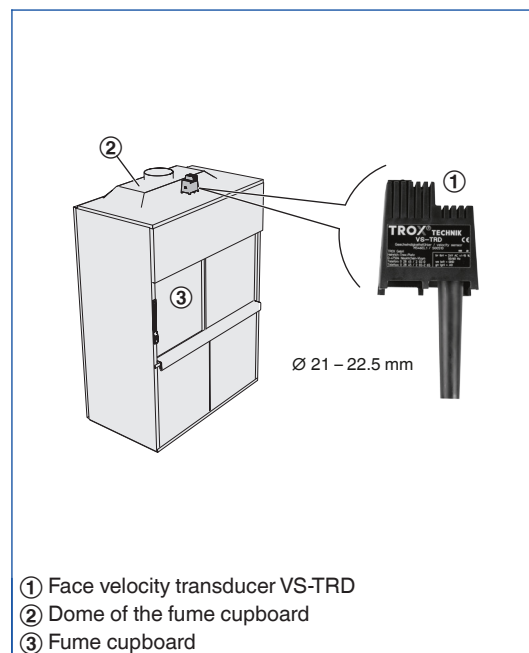

Measurement location of the sash distance sensor (FH-DS, FH-DV)

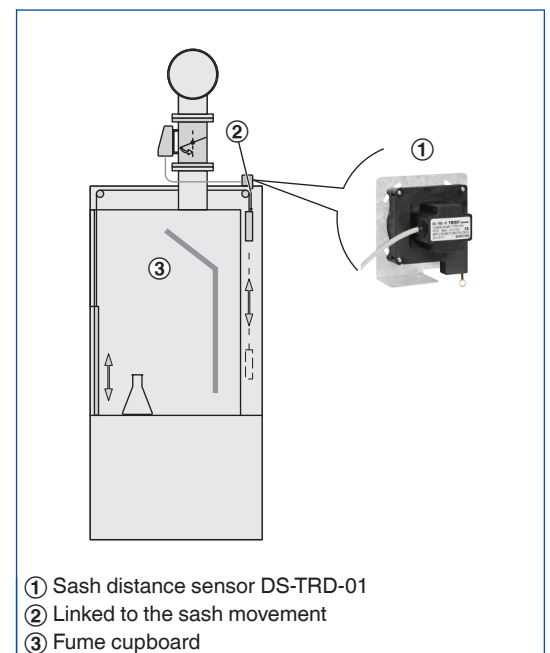

Control panel features

- Push buttons and functions can be configured individually
- Easy to use – available function buttons are visible, unavailable function buttons are not visible
- Buttons for available functions are blue
- Buttons for active functions are white
- Integral service socket for configuration and diagnosis of the controller

BE-SEG-**

- OLED display for system messages, actual face velocity or actual volume flow rate

BE-LCD-01

- Display of actual values, setpoint values, and status messages as text
- Text displays in several languages

EASYPAC control panel BE-SEG-02/03, display and control elements

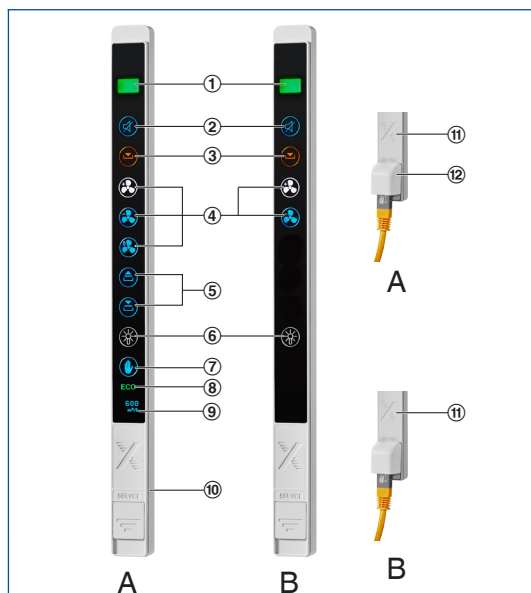

A BE-SEG-02

B BE-SEG-03

- ① Status display (green, yellow, red) with text HIGH and LOW
- ② Alarm acknowledgement
- ③ Sash monitoring warning display
- ④ Selection of operating mode
- ⑤ Automatic sash device
- ⑥ Fume cupboard lighting
- ⑦ Manual control
- ⑧ ECO display
- ⑨ OLED display showing actual volume flow rate, face velocity and status (BE-SEG-02 only)
- ⑩ Connection socket for EASYPAC controller (at rear)
- ⑪ Alarm sander
- ⑫ Connection socket for service and commissioning

EASYPAC control panel BE-LCD-01, display and control elements

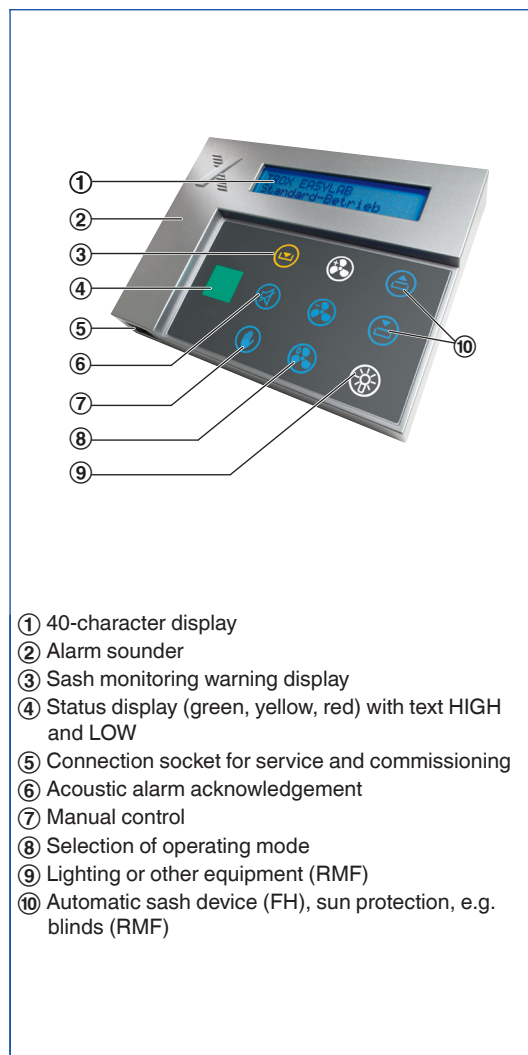

- ① 40-character display
- ② Alarm sander
- ③ Sash monitoring warning display
- ④ Status display (green, yellow, red) with text HIGH and LOW
- ⑤ Connection socket for service and commissioning
- ⑥ Acoustic alarm acknowledgement
- ⑦ Manual control
- ⑧ Selection of operating mode
- ⑨ Lighting or other equipment (RMF)
- ⑩ Automatic sash device (FH), sun protection, e.g. blinds (RMF)